

Data Sheet

# Thermostatic expansion valve Type TD 1 / TDE 1

Version 2

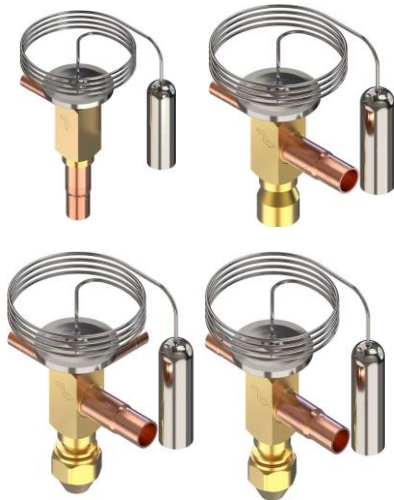

TD 1 / TDE 1 is a thermostatic expansion valve designed to regulate refrigerant injection into evaporators. The injection depends on the refrigerant superheat at the evaporator outlet, where the bulb must be placed.

TD 1 / TDE 1 is constructed for hermetic sealed systems and supplied as angleway and straightway version.

OEM Applications:

- GDM (Glass Door Merchandiser)
- Commercial fridge and freezer
- Heat Pump

## Features

- Refrigerants: R134a, R1234yf, R22, R290, R404A, R407C, R452A, R454C, R455A, R513A. Other refrigerants are on request.
- Rated capacity from 0.87 to 6.86kW / 0.25 to 1.95TR for R290.
- Stainless steel bulb and Danfoss patented bulb strap:
  1. Fast and easy to install
  2. Good temperature transfer from pipe to bulb.
- Supplied with fixed superheat setting as well as adjustable straightway version for setting customization.
- Permanent filter at inlet.
- Optional bleed function.
- Compact and hermetic construction.
- Stainless steel capillary tube
  1. Flexible lightweight capillary tube, tolerates more bending for trouble-free installation and longer life.
  2. Greater resistance to vibration during operation because of low weight
- Laser welded stainless steel power element, capillary tube and bulb:
  1. optimum regulation properties
  2. long life of diaphragm
  3. high pressure strength
- MOP (Max. Operating Pressure) function is available.
- UL Certified

## Functions

Figure 1: Angle way fixed superheat setting

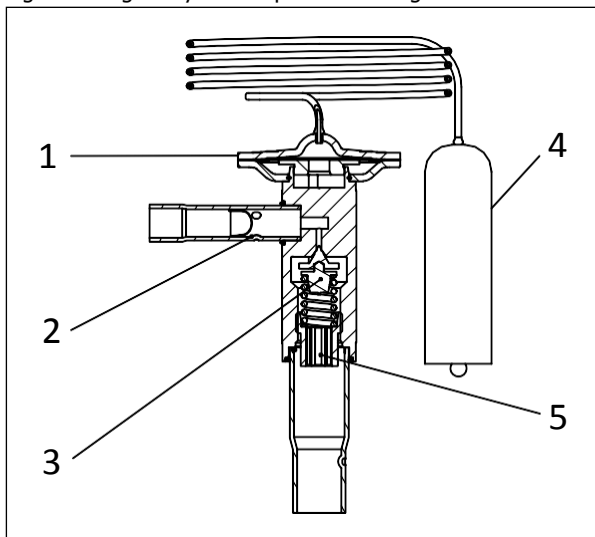

1	Thermostatic element (diaphragm)
2	Strainer
3	Fixed orifice assembly
4	Bulb with capillary tube
5	Locked setting screw

TD 1 / TDE 1 valves have a fixed orifice assembly. Both straight way and angle way configuration are available and the angle way version is designed with fixed superheat setting only.

The valves are available with internal or external pressure equalization. External pressure equalization should always be used on systems with liquid distributors.

The stainless steel capillary tube and bulb with Danfoss patent bulb strap give reliable connection. It gives fast and precise reaction to temperature changes in the evaporator.

## Product specification

### Technical data

Max. bulb temperature: 120 °C / 248 °F  
 Max. valve housing temperature: 150 °C / 302 °F  
 Max. working pressure: PS/MWP = 34 bar / 500 psig  
 Max. test pressure: 37.5 bar / 540 psig  
 Capillary tube length: 0.75 m / 30 inch  
 Bleed: 15% or 30%

Ori- fice No.	R134a		R1234yf		R407C		R290		R404A		R452A		R454C		R455A		R513A		R22	
	KW	TR	KW	TR	KW	TR	KW	TR	KW	TR	KW	TR	KW	TR	KW	TR	KW	TR	KW	TR
0	0.46	0.13	0.36	0.10	0.90	0.26	0.87	0.25	0.83	0.24	0.85	0.24	0.80	0.23	0.95	0.27	0.42	0.12	0.82	0.23
1	0.70	0.20	0.54	0.15	1.31	0.37	1.27	0.36	1.13	0.32	1.17	0.33	1.16	0.33	1.35	0.38	0.63	0.18	1.19	0.34
2	1.19	0.34	0.91	0.26	2.09	0.59	2.02	0.58	1.78	0.51	1.85	0.53	1.83	0.52	2.13	0.61	1.06	0.30	1.89	0.54
3	2.01	0.57	1.52	0.43	3.24	0.92	3.14	0.89	2.37	0.67	2.54	0.72	2.79	0.79	3.15	0.90	1.76	0.50	2.95	0.84
4	2.83	0.80	2.14	0.61	4.51	1.28	4.36	1.24	3.36	0.95	3.58	1.02	3.89	1.10	4.41	1.25	2.47	0.70	4.10	1.16
5	3.81	1.08	2.94	0.84	7.08	2.01	6.86	1.95	5.79	1.65	6.08	1.73	6.20	1.76	7.18	2.04	3.43	0.97	6.43	1.83

#### b NOTE:

This product is approved for R290, R455A, R454C, R1234yf by ignition source assessment in accordance to standard EN ISO80079-36

(1) The rated capacity is based on

Evaporating temperature  $t_e = 5\text{ °C} / 41\text{ °F}$

Condensing temperature  $t_c = 32\text{ °C} / 90\text{ °F}$

Liquid temperature  $t_l = 28\text{ °C} / 82\text{ °F}$

Table 1: Max. operating pressure

Refrigerant	Range K: -25 - +10 °C / -15 - +50 °F	Range AC: -25 - +15 °C / -15 - +60 °F
	MOP point in evaporating temperature $t_e$ and evaporating pressure $p_e$	
	+15 °C / +60 °F	+20 °C / +68 °F
R134a	55 psig / 3.8 bar	70 psig / 4.8 bar
R290	90 psig / 6.3 bar	105 psig / 7.4 bar
R22	100 psig / 6.9 bar	120 psig / 8.1 bar
R407C	95 psig / 6.6 bar	110 psig / 7.8 bar
R404A	120 psig / 8.3 bar	140 psig / 9.9 bar

For R455A, R454C, R1234yf, contact Danfoss for more information.

To avoid charge migration when MOP valves are used, the bulb temperature must be lower than the thermostatic element temperature.

### Valve selection based on capacity calculation

As for extended capacity calculations and valve selection based on capacities and refrigerants, please refer to Coolselector®2. Rated and extended capacities are calculated with the Coolselector®2 calculation engine to ARI standards with the ASEREP equations based on laboratory measurements of selected valves.

## Dimensions and Weight

Figure 2: TD1/TDE1 Adjustable superheat setting, Weight approx. 0.15 kg (2.54 lbs)

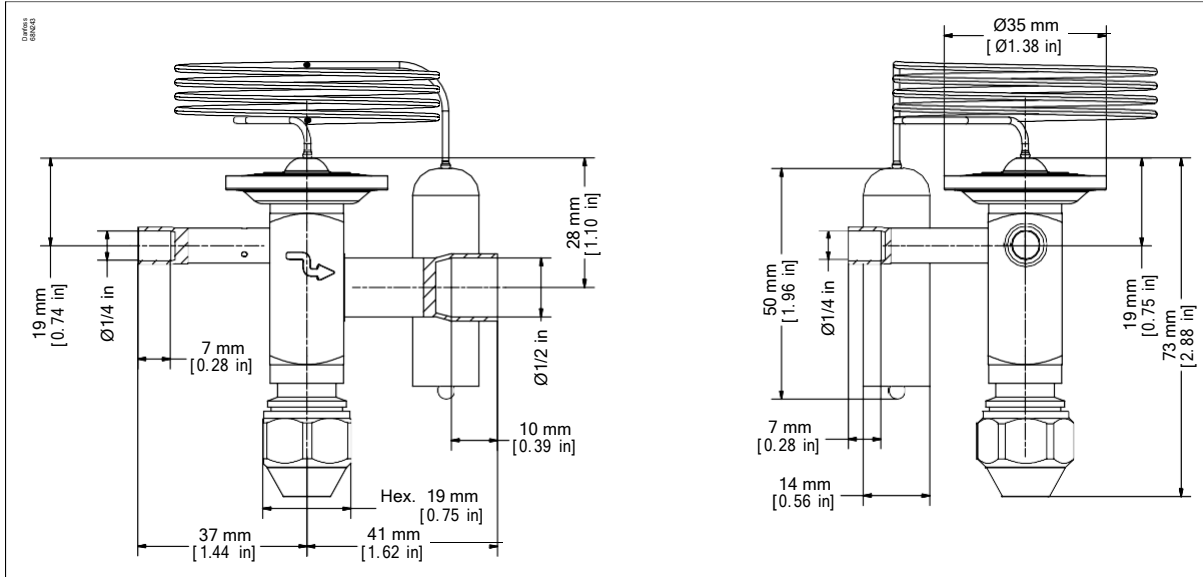

Figure 3: TD1/TDE1 Fixed superheat setting, Weight approx. 0.15 kg (2.54 lbs)

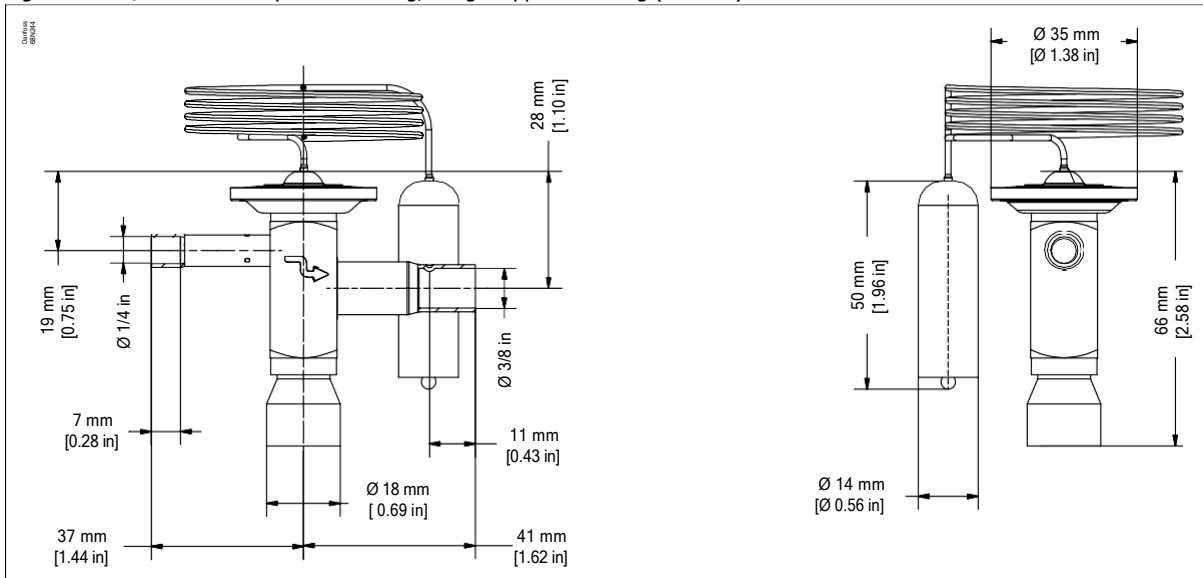

Figure 4: TD1/TDE1 Fixed superheat setting, Weight approx. 0.15 kg (2.54 lbs)

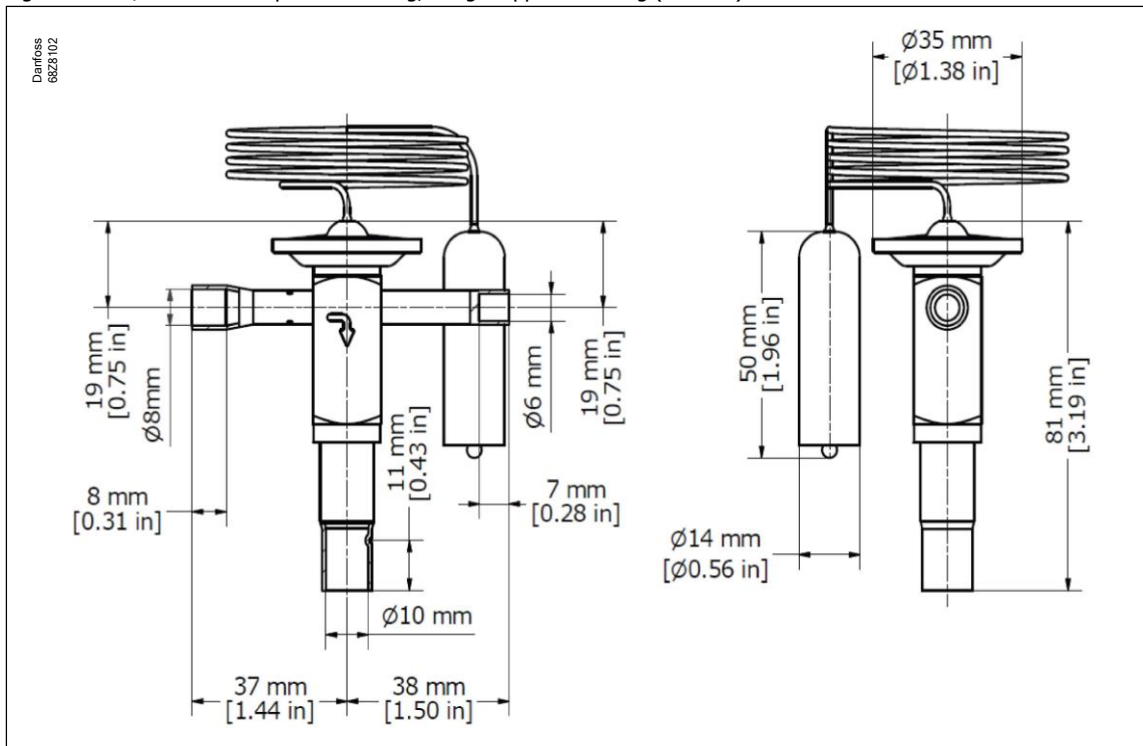
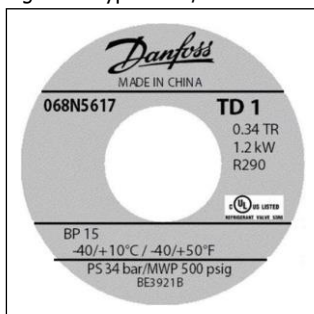

Table 2: Standard Connection Size

Con./Dim.	Size	φD (mm)
Equalization (external)	6mm	6.00
	1/4 in	6.35
Inlet	6mm	6.00
	8mm	8.00
	10mm	10.00
	1/4 in	6.35
	3/8 in	9.52
Outlet	10mm	10.00
	12mm	12.00
	3/8 in	9.52
	1/2 in	12.70

## Identification

Figure 5: Type TD 1 / TDE 1



The valve is fitted with a product label (on top of the diaphragm) which holds information as follows: valve type, rated capacity, refrigerant, evaporating temperature range, MOP point, BP (bleed port %), max. working pressure PS/MWP and production date code.

TD 1 = internal equalization

Thermostatic expansion valve, Type TD 1 / TDE 1

---

TDE 1 = external equalization

0.34 TR = Rated capacity Q in TR

1.2 kW = Rated capacity Q in kW

R290 = Refrigerant

BP15=bleed port 15% (blank stand for no bleed)

-40 / +10 °C / -40 / +50 °F = Evaporating temperature range

068N5617 = Code number

PS 34 bar/MWP 500 psig = Max. Working Pressure in bar and psig

BE3921B = Production date code (BE = China, 39 = Production week, 21 = Year 2021, B = Tuesday)

## Ordering

Figure 6: TD 1 / TDE 1



As the TD 1 / TDE 1 valve is typically an OEM valve, limited code number programme has been set up.

Other code numbers are available on demand.

The valves including bulb strap are supplied in multi pack or industrial pack.

Multi pack: 20 pcs pr. full pack, min. order quantity = 1 pcs.

Industrial pack: 32 pcs pr. pack (min. ordering quantity). Please contact Danfoss.

Table 3: Range N: -40 – +10 °C / -40 – +50 °F and Range AC: -25 – +15 °C / -15 – +60 °F with MOP 20 °C / 68 °F

Refrigerant	Type	Flow Direction	Orifice no.	Range	Rated Capacity		Bleed	Connection ODF inlet*outlet		Code no. Multi pack
					TR	kW		[inch]	[mm]	
R134a	TD1	Angleway	0	N	0.46	0.13	–	1/4*3/8		068N5602
	TD1	Angleway	1	N	0.70	0.20	15%	1/4*3/8		068N5614
	TD1	Angleway	2	N	1.19	0.34	15%	1/4*3/8		068N5656
	TD1	Angleway	3	N	2.01	0.57	15%	1/4*3/8		068N5665
	TD1	Angleway	4	N	2.83	0.80	15%	3/8*1/2		068N5692
	TD1	Angleway	5	N	3.81	1.08	15%	3/8*1/2		068N5695
	TD1	Angleway	3	AC	2.01	0.57	–		6*10	068N5668
	TD1	Angleway	4	AC	2.83	0.80	–		10*12	068N5684
R290	TD1	Angleway	0	N	0.87	0.25	–	1/4*3/8		068N5603
	TD1	Angleway	1	N	1.27	0.36	–	1/4*3/8		068N5607
	TD1	Angleway	2	N	2.02	0.58	–	1/4*3/8		068N5634
	TD1	Angleway	3	N	3.14	0.89	–	1/4*3/8		068N5662
	TD1	Angleway	4	N	4.36	1.24	–	3/8*1/2		068N5690
	TD1	Angleway	5	N	6.86	1.95	–	3/8*1/2		068N5697
	TD1	Angleway	2	AC	2.02	0.58	–		6*10	068N5648

The rated capacity is based on: Evaporating temperature  $t_e = 5\text{ °C} / 41\text{ °F}$ ,

Condensing temperature  $t_c = 32\text{ °C} / 90\text{ °F}$ ,

Refrigerant temperature ahead of valve  $t_1 = 28\text{ °C} / 82\text{ °F}$

Table 4: The bulb strap can also be sold separately

Code no.	Description	Pack mode	Quantity/pack
068U3505	Bulb strap 0.4mm Max.28 mm tube	I	45
068U3507	Bulb strap 0.4mm Max.28 mm tube	M	25

Figure 7: Bulb strap

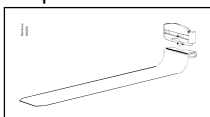



## Certificates, declarations and approvals

The list contains all certificates, declarations, and approvals for this product type. Individual code number may have some or all of these approvals, and certain local approvals may not appear on the list.

Some approvals may change over time. You can check the most current status at [danfoss.com](https://danfoss.com) or contact your local Danfoss representative if you have any questions. [expansion valve Danfoss in arantabrid](#)

Table 5: Certificates, declarations and approvals

Document name	Document type	Document topic	Approval authority
033F4011	Manufacturers Declaration	RoHS	Danfoss
033F4006	Manufacturers Declaration	China RoHS	Danfoss
067R1068	Manufacturers Declaration	PED	Danfoss
SA7200	Third Party certificate	UL	UL LLC